



Economy ~ Ecology ~ Excitement™

What sets us apart?

- Full recharge in 8 hours from standard 120-volt outlet*
- Top Speed: 70+ MPH
- Capacity: Driver plus two
- Range: Up to 325 miles per day*
- The equivalent of up to 225 MPG
- Safe and fun to drive
- Affordable



*Depending on battery options & driving conditions. Specifications are subject to change without notice.



Our Goal:

The Defiant EV³ Roadster© is a sporty electric roadster that is an innovative combination of the best of today's technology and sleek, aerodynamic styling.

Performance:

The Defiant EV³ Roadster© brings an aggressive approach to styling, performance, efficiency, and affordability to the electric eco-sports car market. While the roadsters provide excellent performance with the standard Li-Ion batteries larger battery systems are available.

Who We Serve:

Our primary market is the commuter driving less than 100 miles a day. The MSRP for the Defiant EV³ Roadster© is affordable for the average person. *Financing is available.*

Shockwave Motors, Inc.



5840 Brights Pike

Russellville, TN 37860

Phone: 423.754.6067

www.ShockwaveMotors.com

Shockwave Motors, Inc.

Get charged up and save the planet one mile at a time!™



©2015 Shockwave Motors, Inc.

Home of the

Defiant EV³ Roadster

SHOCKWAVE MOTORS

At Shockwave Motors, Inc. we have designed and built an efficient, three-passenger, electric roadster that is an innovative combination of the best of today's technology and sleek, aerodynamic styling.

With the help of an international team of engineers, we have designed and constructed a "purpose built" electric car as opposed to a typical electric car that is essentially a conversion of a standard gasoline powered car. We started with a clean sheet of paper and an open mind. The Defiant EV³ Roadster© is designed from the ground up to capitalize on the efficiencies of an electric car; with an eye on a sporty design, that is simple to manufacture and repair.

Contemporary market research has shown the need for an affordable, electric commuter. A vehicle that is capable of highway speeds and a daily range of at least 100 miles. Our primary market is a commuter living in or around a major metropolitan area. The base price is low enough for the average person to afford. Our high performance Li-Ion Roadster provides a superior driving experience.

To be placed on our "interest list" please send an e-mail to:
John@ShockwaveMotors.com

DEFIANT EV³ ROADSTER©

The Defiant EV³ Roadster© is a ground-up design, with three wheels. The goal was to create a highly efficient electric vehicle able to carry a driver and two passengers at highway speeds (in excess of 70 MPH), with a daily range of up to 200 miles*. The use of three wheels reduces rolling resistance at slow speed and the aerodynamic design reduces drag at higher speeds.

Frame and Chassis Engineered for Safety
Our ground-up design and tubular steel construction gives us a lightweight and strong chassis with racecar like passenger protection. The low center of gravity provides a smooth and stable ride, even under adverse weather conditions.

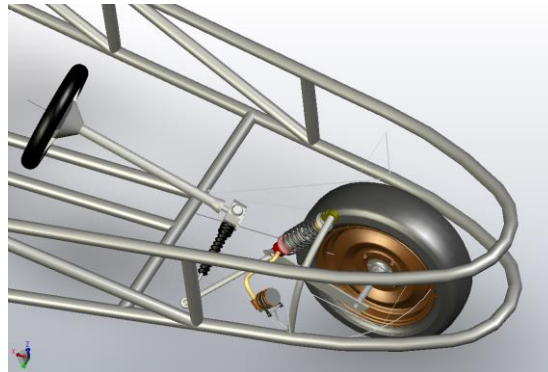

The proof-of-concept electric roadsters have undergone several years of performance testing in the hills of east Tennessee. At lower speeds (25 MPH), we are achieving the equivalent of over 350 miles per gallon! At highway speeds, we are consuming less than 200 watt-hours per mile.

MEET THE TEAM



John McMillian has more than 40 years of experience with electric vehicles. After majoring in Transportation and earning an MBA from the University of Tennessee, John spent eight years on active duty with the Air Force. He is the author of "Electric Cars: The switch is on!" and "The Leader's Guide to Quality in America".



Graduate from Laval University, in Quebec City, Normand Rheault has a long career as a management consultant. He has also held management positions at Hyundai Motors Canada, Bell Helicopter, Textron, and Rolls-Royce Limited. He was key member of the executive team of one of the largest engineering firms in Canada.



Carrie Fair has many years of firsthand experience in professional sales and media relations. She is responsible for securing media coverage with both local and national media visibility and serving as our spokesperson; additionally, she oversees our social media effort.